

WHE LED Series

Wall Harsh Environment



WHE LED Series

SPECIFICATIONS

- Heavy-Duty Die Cast Aluminum Housing and Top Frame (Optional)
- Gray Powder Coat Finish, Optional Custom Color
- Clear Polycarbonate Vandal-Resistant Lens or Opal Polycarbonate Vandal-Resistant Lens
- CRI LED Aluminum Substrate Board
- Universal Volt LED Driver 120-277V
- 4K or 5K LED Color Options
- Optional Surge Protection

APPLICATIONS

- General Area/Harsh Environment Areas
- Airports, Walkways, Parking, Tunnels
- Schools and Commercial Buildings
- Warehouse/Industrial Facilities

ELECTRICAL

- 120-277V 50/60Hz
- 22 SystemWatts; 3,332 Lumens
- 37 System Watts; 5,538 Lumens

INSTALLATION

- Mount over Recessed Box or with Surface Conduit
- Quick Mount Bracket Optional
- Can be Tapped for Side Conduit Entry (Conduit by Others)

CERTIFICATIONS/LISTINGS

- CSA Listed
- IP66
- Listed for Wet Locations



PROJECT _____ TYPE _____

QTY _____ NOTES _____ APPROVAL _____

ORDERING/SPECIFYING INFORMATION:

EXAMPLE: WHE L 22 UNV 50K

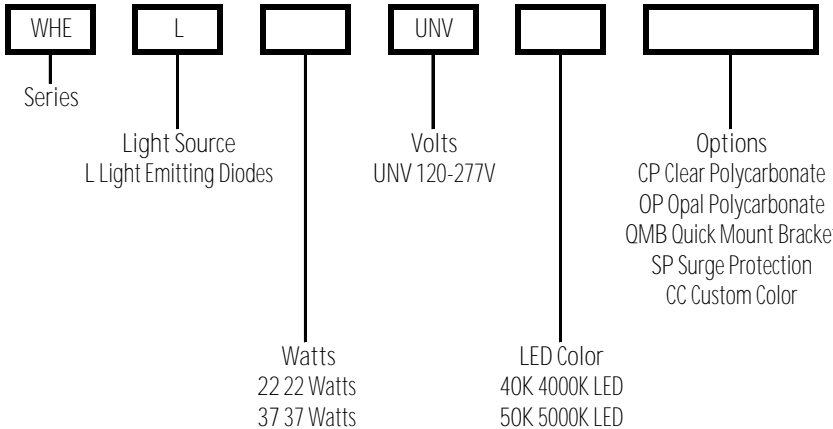

SPECIFICATIONS

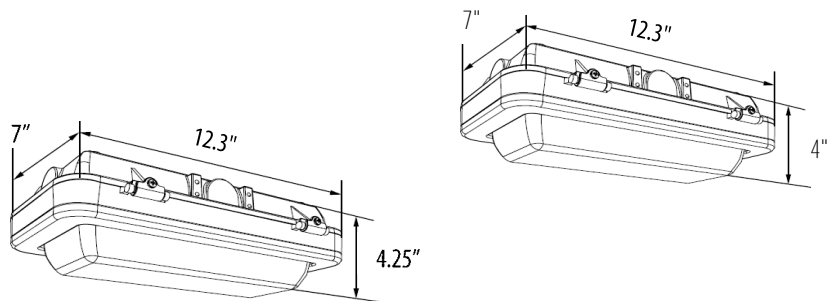

OPTIONS/ACCESSORIES

QMB Quick Mount Bracket

