

WSL Series

Large Semi-Cut Off Wall Pack



WSL Series

SPECIFICATIONS

- Die Cast Aluminum Housing
- Tempered Clear Glass Lens
- Internal Aluminum Reflector (Non-LED)
- Bronze Powder Coat Finish, Optional Custom Color
- HID Porcelain Medium Base 4KV Socket
- Stainless Steel Hardware
- Multiple Light Source Options
- 4K LED Color
- Universal Volt LED Driver 120-277V
- Optional Surge Protection
- Optional Photocell

APPLICATIONS

- General Area, Facade Lighting, Entry Lighting
- Platforms, Walkways, Parking, Tunnels
- Schools and Commercial Buildings
- Commercial, Warehouse, Industrial Facilities

ELECTRICAL

- 120-277V: LED 58W
- 120V: HPS 35, 50W, 70W, 100W & 150W
- Quad Volt: MH & HPS 50W, 70W, 100W, & 150W

INSTALLATION

- Mounts Over Recessed Box or with Surface Conduit

CERTIFICATIONS/LISTINGS

- CSA Listed
- Listed for Wet Locations



PROJECT _____ TYPE _____

QTY _____ NOTES _____ APPROVAL _____

ORDERING/SPECIFYING INFORMATION:

EXAMPLE: WSL M 50 Q L

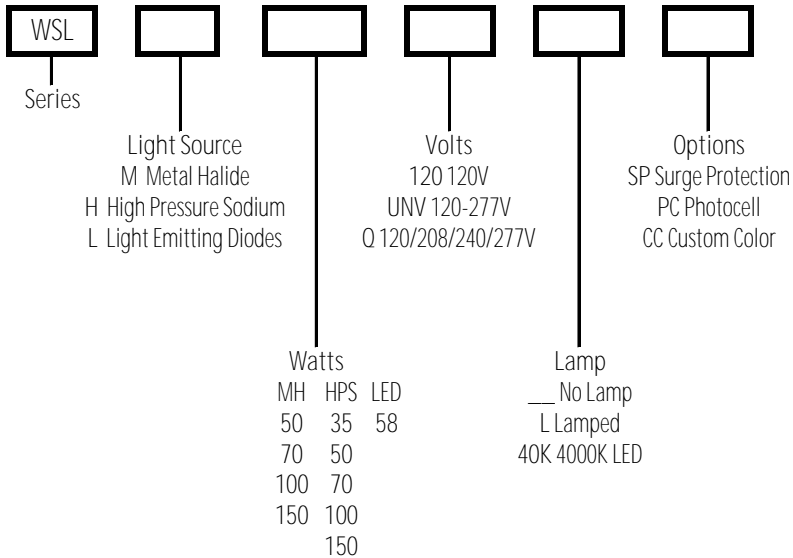

SPECIFICATIONS

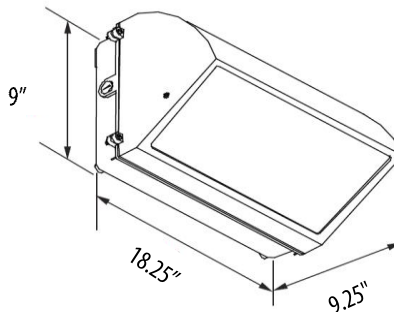

OPTIONS/ACCESSORIES

Specifications Subject to Change

