

WAL Series

Large Architectural Wall Pack



WAL Series

SPECIFICATIONS

- Die Cast Aluminum Housing
- Borosilicate Molded Glass Lens
- Bronze Powder Coat Finish, Optional Custom Color
- Internal Aluminum Reflector (Non LED)
- HID Porelain Mogul Base 5KV Socket (Non LED)
- Stainless Steel Hardware
- Multiple Light Source Options
- 3K, 4K or 5K LED Color Options
- Universal Volt LED Driver with Optional Dimming
- Optional Emergency Battery (LED)
- Optional Photocell
- Optional Surge Protection
- Optional Wire Guard

APPLICATIONS

- General Area, Facade Lighting, Entry Lighting
- Platforms, Walkways, Parking, Tunnels
- Schools and Universities
- Commercial, Warehouse, Industrial Facilities

ELECTRICAL

- 120-277V: LED 58W
- Quad Volt: HPS 100W, 150W, 250W & 400W
MH 100W & 150W & PMH 250W, 320W & 400W
- 480V: MH 100W & 150W, PMH 250W, 320W & 400W & HPS 100W, 150W, 250W & 400W

INSTALLATION

- Mounts Over Recessed Box or with Surface Conduit

CERTIFICATIONS/LISTINGS

- CSA Listed
- Listed for Wet Locations

**ALL-SITE
LIGHTING**

PROJECT _____ TYPE _____

QTY _____ NOTES _____ APPROVAL _____

ORDERING/SPECIFYING INFORMATION:

EXAMPLE: WAL P 250 Q L

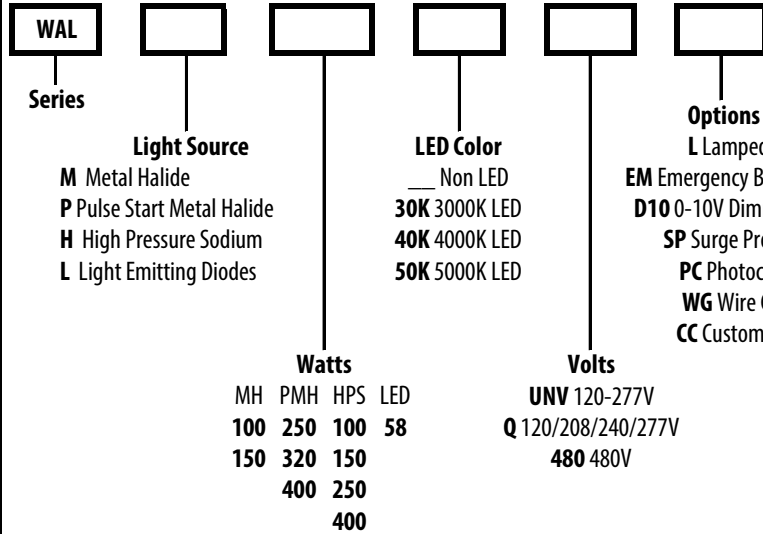

SPECIFICATIONS

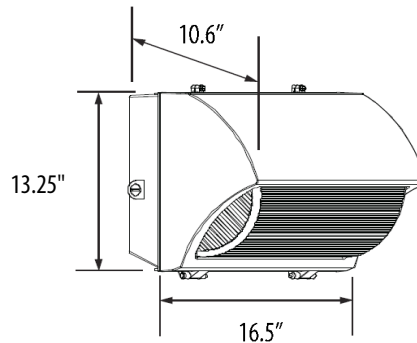

OPTIONS/ACCESSORIES



WG Wire Guard

Specifications Subject to Change

